

Installation, use and maintenance,
risk assessment manual

Errex *boltless shelving*

DALMINE 
LOGISTIC SOLUTIONS



Contents

GENERAL INFORMATION

Introduction	2
General rules for the use of Errex storage system	2
Limits of supply and use	2
Manufacturing standards	3
User's responsibilities	3
List of components	4

INSTALLATION

Installation phases	6
Accessories	10
Tightening torque tables	12

INSTRUCTIONS FOR PROPER MAINTENANCE

Scheduled maintenance table	13
-----------------------------	----

RISK IDENTIFICATION, ANALYSIS AND ASSESSMENT

Semi-qualitative scales	14
Assignment of risk categories	14

General Information

INTRODUCTION

The maintenance and user manual contains the main instructions for the correct assembly and use of the shelving. In particular the manual contains:

- the procedure of assembling the shelving;
- the maximum amount that the shelving can be out-of plumb or misaligned and the method of measuring and checking this during the lifespan of the shelving;
- the mandatory adhering to all the criteria for the safety of personnel assigned to the assembly, according to the current accident-prevention regulations, including the use of safety clothing and equipment;
- the mandatory displaying of the “Maximum Load” notices in full view;
- the forbidden altering of the designated structure without the prior agreement of the manufacturer;
- the necessity of replacing any parts which become damaged.

GENERAL RULES FOR THE USE OF ERREX STORAGE SYSTEM

Use

Errex shelving consists of vertical parts called abutments and horizontal parts called shelves, pur pose made for the storage of loose material. Shelving equipped with the appropriate accessories can also be used to stockpile boxes, packages etc.

The goods must be installed on the shelves in such a way that the load is evenly distributed and stable.

Overloads

Avoid overloading the structure with more than the “Maximum Load” indicated on the notices and in the technical documentation (manual). It is essential to verify that the loads do not exceed the limits indicated in the manual. In general, the maximum load of the horizontal structures (shelves, ledgers) refer to “uniformly distributed loads” conditions. Concentrating the loads and/or not distributing them evenly can still overload the structure, even if the total weight is less than the maximum limit.

Dynamic load

The loads must be positioned on the structure avoiding any sudden movements or unexpected manoeuvres.

The shelving subject to dynamic loads (warehouses exposed to wind, snow or other seismic activities) will be designed accordingly.

Variations in layout

Any changes in the layout of the shelving should be checked to see whether it is compatible with the maximum load of each section and the overall structure. It is important to note that when shelves are removed or are altered in height, e.g. in order to stow taller items, the maximum load capacity of the abutments decreases.

Please contact the technical office at DalmineLS to check each individual case.

Collisions

Avoid bumping the structure with any methods of transportation. In the case of accidental damages, establish the extent of the damage

and if necessary replace the damaged parts. In the case of repeated bumps, suitable protection should be put in place.

Staff training

The person in charge of use of the warehouse must be fully informed of its technical characteristics. The load-bearing capacities of the components and structures are shown in the layout drawings and on the load capacity warning signs provided.

The basic information of which all operatives must be aware is:

- maximum loading of the shelving
- dimensions and type of shelving
- maximum capacity of the abutments
- maximum capacity of the vertical poles
- the height from the ground of the first shelf
- the distance between each shelf
- the number of shelves

Staff must be trained to:

- use the handling equipment correctly
- inform those in charge immediately in the event of collisions with structures
- inform those in charge of any malfunctions noted
- use the personal protection equipment during installation, maintenance and handling operations

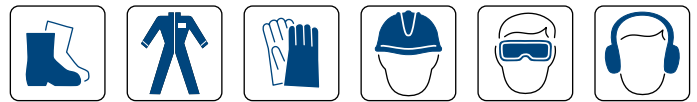

Forbidden Procedures

The following are forbidden on warehouse storage systems supplied by DalmineLS:

- welding
- fitting of ties for use for installing systems of any kind

All such operations must be included in the installation design and approved in writing by DalmineLS.

Assembly

The shelves must be assembled under the supervision of the manufacturer or the user by means of suitably trained and qualified staff.

During the assembly the instructions in the users’ manual must be strictly followed. The vertical alignment of the shelves must fall within the specified parameters.

Once the structure has been assembled the “Maximum Load” notices must be clearly displayed as outlined by the current regulations (D.P.R. 27 April 1955 n. 547 - Art. 9).

LIMITS OF SUPPLY AND USE

Errex shelving has been designed for use inside industrial buildings. Specific designs must be drawn up for outdoor shelving exposed to extreme climatic conditions, for example: wind, snow, or earthquakes. The reinforced concrete flooring must be prepared by the user and should be completely level with a maximum discrepancy of ± 1 cm and must be able to support the total weight held by the shelves.

Care must be taken to spread the load.

Floors other than those made of reinforced concrete are not recommended.

The load on the shelving must not exceed the "Maximum Load" indicated on the notices which must always be clearly displayed.

MANUFACTURING STANDARDS

UNI EN 15629:2009 dated 19/03/09

Steel static storage systems - Specification of storage equipment.

UNI EN 15635:2009 dated 19/03/09

Steel static storage systems - Application and maintenance of storage equipment.

USER'S RESPONSIBILITIES

Errex users have a number of specific responsibilities with regard to the assurance of conditions of compliance.

They are responsible for:

- compliance with the regulations in the country of installation;
- compliance with the supplier's detailed assembly and installation instructions, which must be followed correctly when installation is carried out by the user or its contractor;
- compliance with specifications concerning the maximum weight and overall dimensions of the goods or load units for storage;
- compliance with limits concerning anchoring to the ground, evenness of floor, floor load-bearing capacity, etc.;
- labelling any specific loads to be handled with care;
- care not to drag or push goods when in contact with the warehouse's structural elements;
- the provision of the essential recommended turning spaces, to minimise the risk of collision between loads, or between loads and the warehouse storage fittings;
- the use of equipment compliant with the contract specifications;
- regular inspections of the Errex warehouse throughout its working life to ensure that any damage is repaired and damaged components are replaced with new parts supplied by the same producer.

List of main components

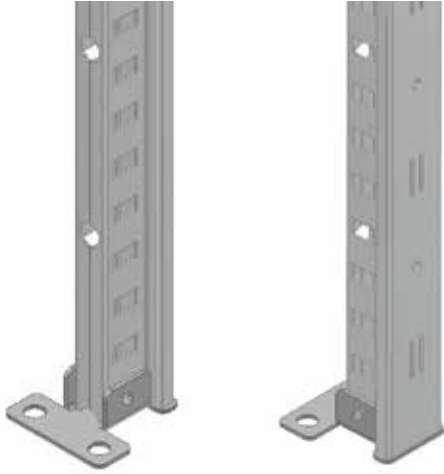

Simple base element and upright

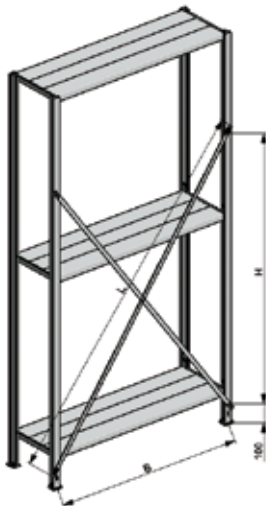

Bracing

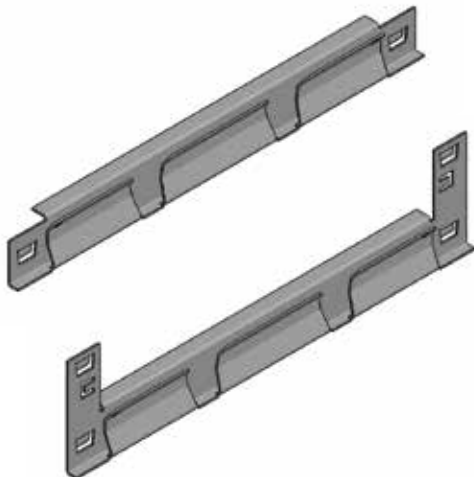

Ledgers

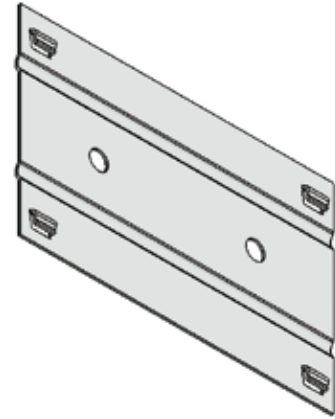

Side plate

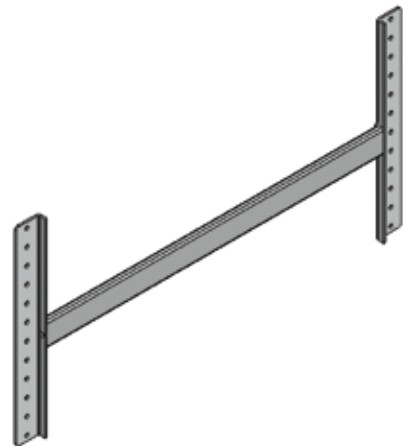

Bracing stringer

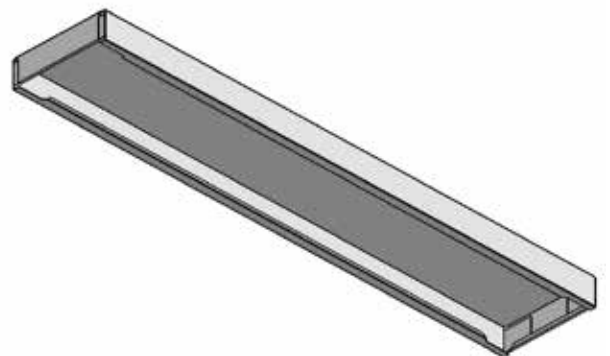

Panel

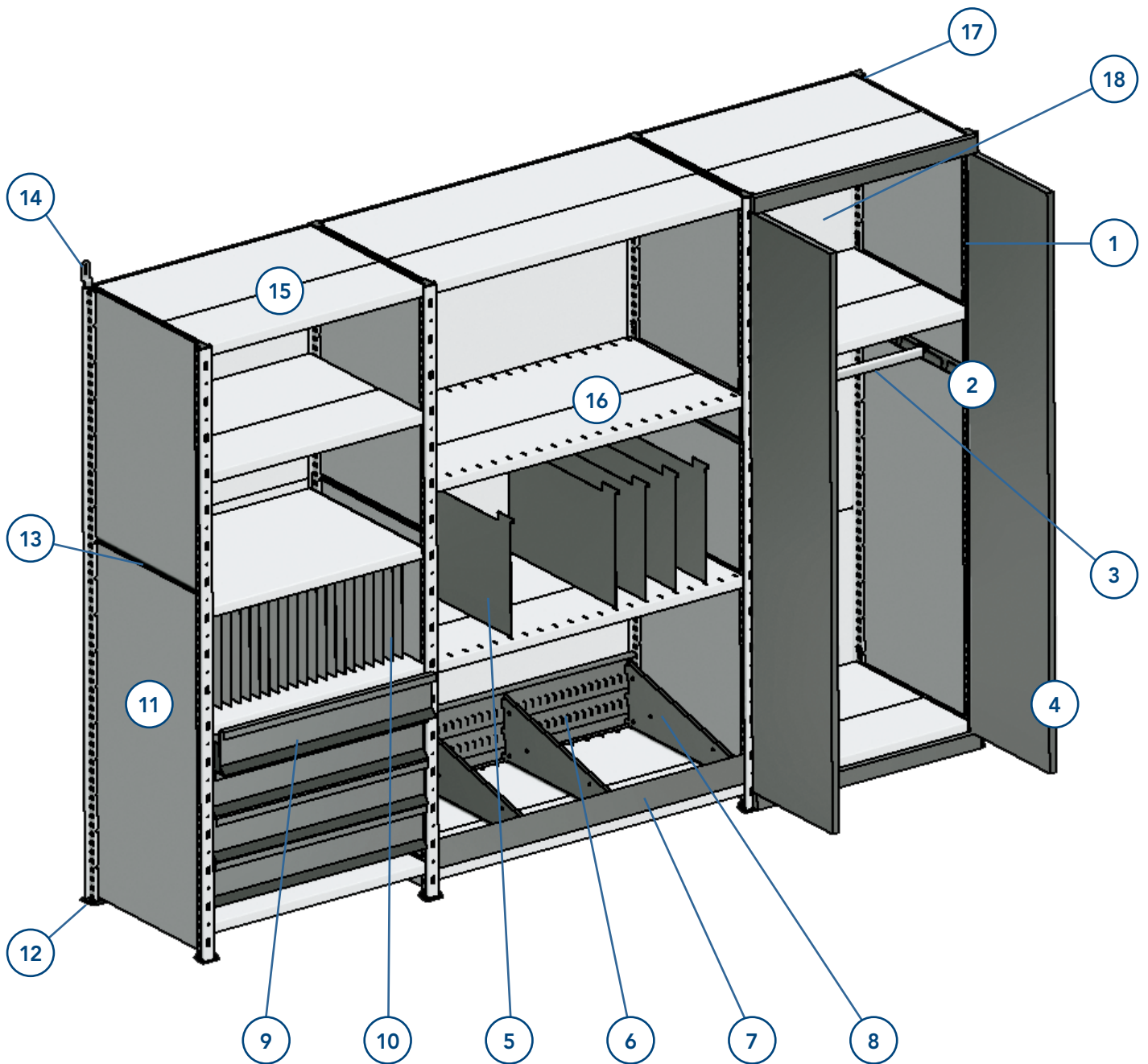

- | | |
|---------------------|-------------------------|
| 1 Upright | 10 Folders rack |
| 2 Ledger | 11 Side board |
| 3 Wardrobe tube | 12 Base element |
| 4 Shutters | 13 Side boards junction |
| 5 Vertical dividers | 14 Wall fixing |
| 6 Rear board | 15 Panel |
| 7 Front board | 16 Panel TS |
| 8 Mobile divider | 17 Upright plug |
| 9 Drawers | 18 Back board |

Installation

INSTALLATION PHASES

Axes markings

The first part of the assembly consists of marking the axes. The operation consists of marking the ground in rectangles in accordance to the layout of the various legs of the shelving.

Upright frames assembly

- 1) Assemble the base using a rubber hammer.
- 2) Assemble the lateral plates using a rubber hammer if required.
- 3) Assemble the ledgers according to the height of the shelves, using a rubber hammer if necessary.
- 4) Insert reinforced base where required.
- 5) Attach the reinforcement for each upright with M5x20 screws.



1



2



3



4

- 6) Carry out the assembly for the required number of upright frames.

7-7a) Check the vertical and horizontal alignment in accordance to the instructions shown on the right.

VERTICALITY: $v < H/1000$

v = longitudinal and side out-of-perpendicularity

H = structure height

ALIGNMENT: $a = \pm 5 \text{ mm}$

a = maximum structure drift lengthwise and sidewise

HORIZONTALITY: $o = \pm 5 \text{ mm}$

o = maximum drift of flat parts, when compared with the original blueprint

Remarks: equipment tolerances are given case by case.



5



6

Panel assembly

8) Do not use force when positioning the panels.

9) It is possible to use type TS panels as vertical separators.

Assembly of auxiliary parts

10-10a) If required, attach the diagonal bracing with M5x20 screws.

11) If required, attach the bracing stringer with M5x20 screws on each side.

12) Position the vertical dividers in the appropriate slots.

13) Position the small back panels.

14) Insert the mobile dividers.



8



9



10



10a



11



12



13



14

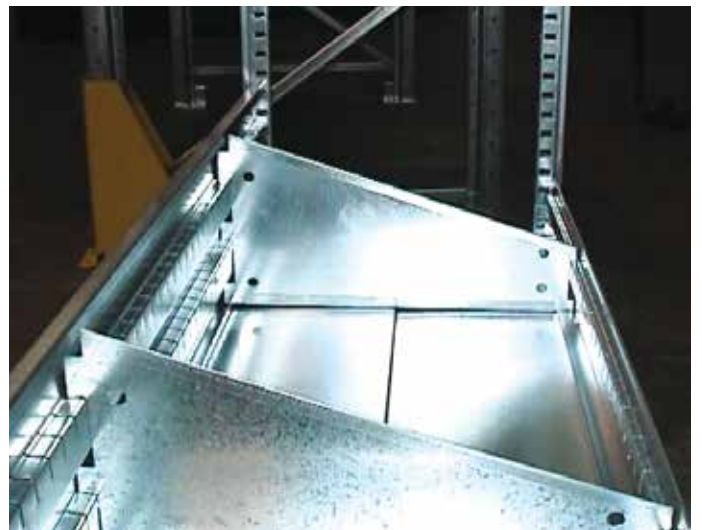

15

15) Complete the assembly with the small front panels.

16) Insert the bottom wall.

17) Position the side panels.

18) Complete the lining.

19) If required, install the clothes pole.

20) Attach the ladder support with M5x20 screws.

21) Position the support pipe for the ladder.



16



17-18



19



20



21

Accessories

WING DOOR

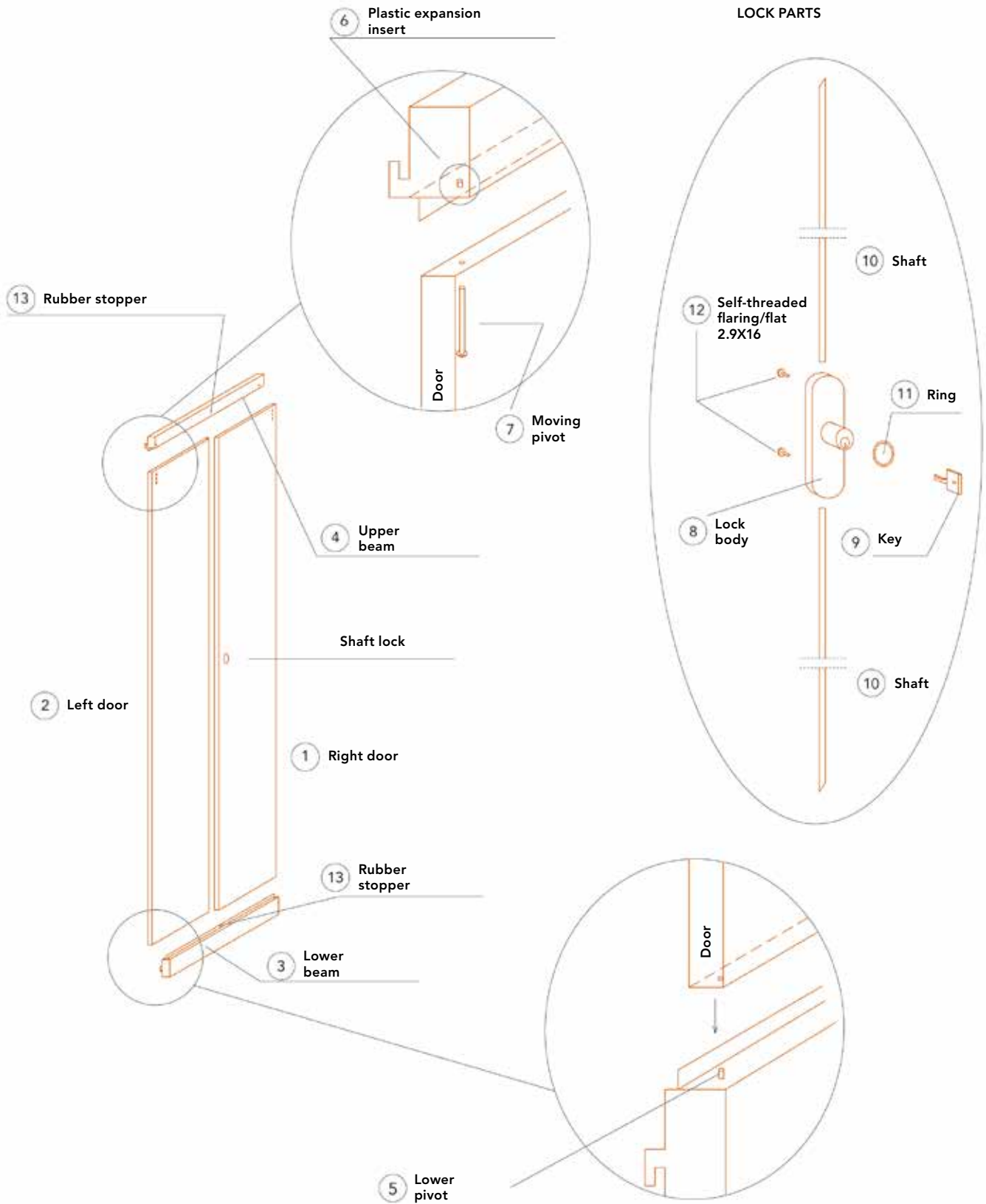

DRAWER H=170 MM FOR ERREX 1000X600 MM

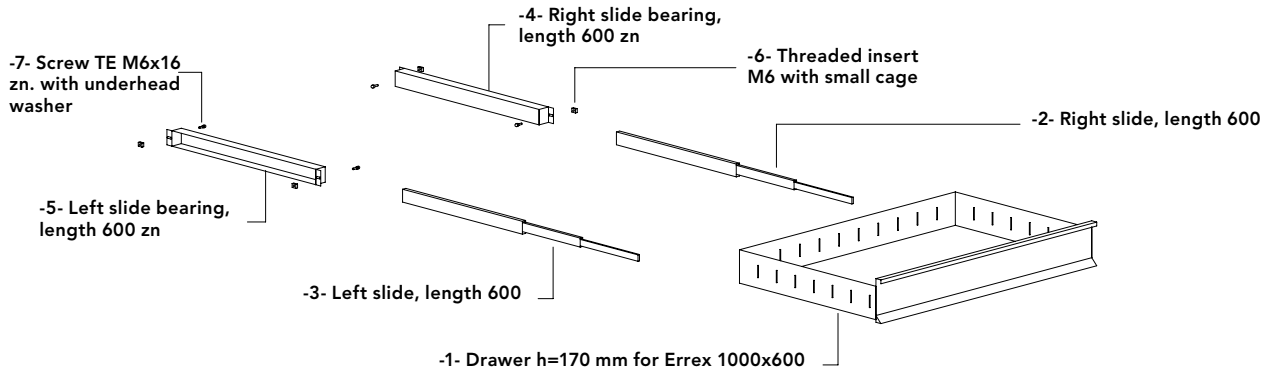

DRAWER ACCESSORY H=120 MM FOR ERREX 1000X600 MM

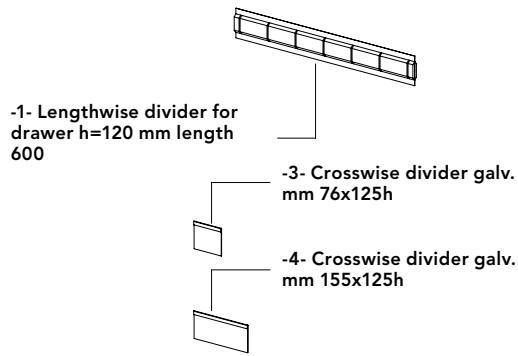

DRAWER ACCESSORY H=170 MM FOR ERREX 1000X600 MM

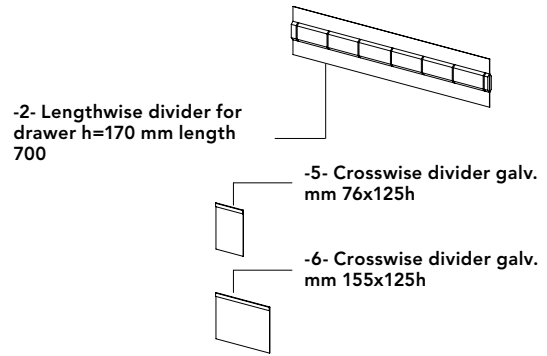

FOLDER RACK MADE OF 10/10 GALVANIZED STEEL PLATE, FOR 850/1000/1025-MM WIDE SPANS

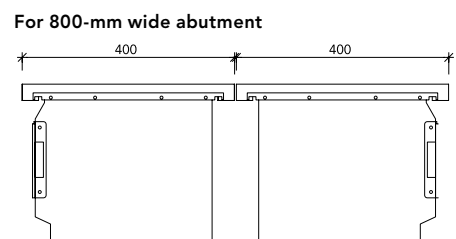
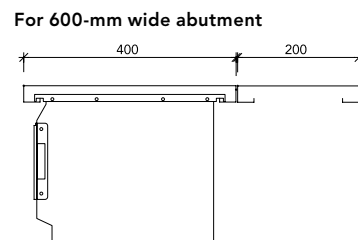
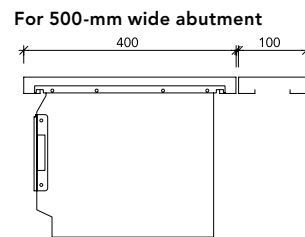
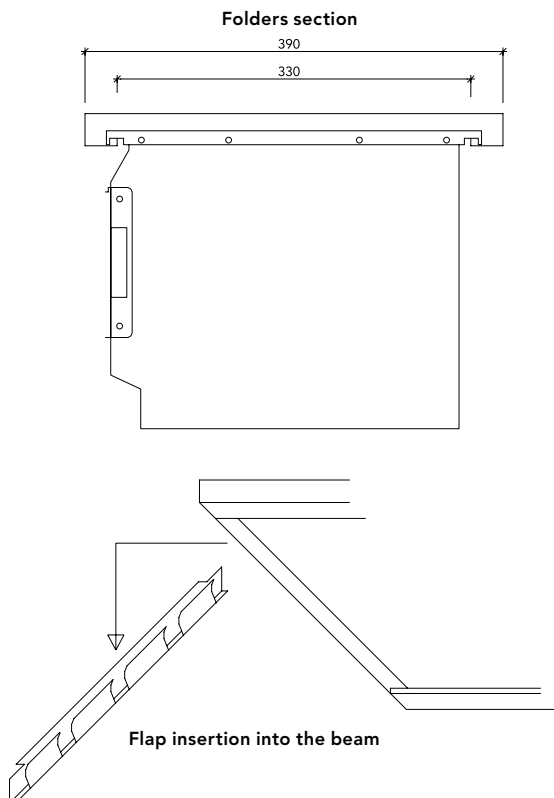

TIGHTENING TORQUE TABLES

- For the fastening sequences for **mechanical expanders**, the instructions supplied by the suppliers must be strictly adhered to.
- Hexagonal head screws UNI 5737 and similar, cylindrical head screws with hexagonal hole UNI 5931.
- Friction coefficient underhead and on the threads $\mu = 0,14$ (black phosphate screws lubricated with oil before insertion).
- Torque wrench setting applied gradually with a torque spanner, not with a rigid spanner.
- If the tightening is executed with a rigid spanner, reduce the value M by 10%.
- For cadmium screws, reduce the value M by 20%.
- For hexagonal head screws, increase the value M by 5%.

**MINIMUM TIGHTENING TORQUES FOR SHEAR JOINTS,
WITH CLASS 8.8 SCREWS**

d (mm)	Area (mm ²)	Ts (N x m) = 8,8
5	14	3
6	20	5
8	36	12
10	58	20
12	84	45
14	115	72
16	157	112
18	192	154
20	245	218
22	303	298
24	353	350

Instructions for proper maintenance

Constant, systematic checks are required to ensure that the structures remain in good condition over time.

Scheduled maintenance table

DESCRIPTION OF OPERATION	FREQUENCY	PROCEDURE
Inspection for collision damage	From 6 months to one year	Check regularly for permanent dents of varying extent caused by collisions. On systems with a high turnover rate, a thorough visual inspection should be performed every 6 months. For other systems, the inspection can be performed annually. The damaged parts must be replaced with genuine components.
Check that structure is vertical	Every 2 years	Checks that the structures are vertical must be performed by inspecting the structures of both ends of the system in both directions (lengthways and crossways). Consider the assembly tolerances stated in the manual. Restore structures to the vertical position using shims. <i>Tools required:</i> <i>Plumbline.</i>
Inspection of anchoring to the foundations	every 2 years	Check the tightening torque of the expansion plugs.
Inspection of galvanised and painted finishes	From one to 5 years	Check the condition of the galvanised or painted finishes at a frequency decided depending on the installation location: in corrosive environments, inspect every year; in normal indoor environments, the inspection interval may be as long as 5 years.

Risk identification, analysis and assessment

The method adopted for the identification of risks is based on the identification of processes involved in the construction of the system.

The risks were identified for each process, and then evaluated on the basis of the legal requirements and the rules of good practice, the environmental context, and the simultaneous and/or consecutive presence of different contractors and/or different processes.

Semi-qualitative scales

Risks were assessed with the aid of the two semi-qualitative scales:

- **D index scale:** indicates the potential damage related to the risk
- **P index scale:** indicates the probability and frequency with which an event may occur

For allocation of the values 0,1, 2 and 3, the occurrence of even just one of the conditions stated in the “criteria” column is sufficient. Naturally, the allocation of one of the values does not imply a prediction that all the conditions corresponding to the value chosen, listed in the “criteria” column, will apply.

D INDEX (POTENTIAL DAMAGE) SCALE	
VALUE	CRITERIA
3	Damage causing irreversible injuries (death, anatomical and/or functional loss). Injuries producing temporary disability with initial prognosis of recovery in > 40 days may occur. There is a correlation between the procedure and the possibility of death or permanent disability.
2	Injuries producing temporary disability with initial prognosis of recovery in > 21 days may occur. There is a correlation between an accident during a stage of the process and the risk of injury with partial or total stoppage of operations lasting > 30 days and/or the production of limited environmental contamination.
1	Injuries producing temporary disability with initial prognosis of recovery in ≤ 21 days may occur. There is a correlation between an accident during a stage of the process and the risk of injury with partial or total stoppage of operations lasting > 1 and ≤ 30 days.
0	Injuries producing temporary disability with initial prognosis of recovery in ≤ 3 days may occur. There is a correlation between an accident during a stage of the process and the risk of injury with partial or total stoppage of operations lasting ≤ 1 day.

P INDEX (PROBABILITY – FREQUENCY OF EVENTS) SCALE	
VALUE	CRITERIA
3	There is a direct correlation between the risk factor and the cause related to a form of damage. Damage has already occurred due to the problem identified (accidents, injuries, occupational illnesses). There is a correlation between the procedure and/or the risk factor and the deterioration of the accident rate and/or the rate of occupational illness over a significant period (three to five years). The likelihood of an accident is $\geq 2 \cdot 10^{-2}$
2	The risk factor may cause damage, although not automatically or directly. Occasions on which the problem noted has led to the damage are recorded. There is a correlation between the procedure and/or the risk factor and a random trend in the accident rate and/or the rate of occupational illness over a significant period (three to five years). The likelihood of an accident is $< 2 \cdot 10^{-2} \text{ e } \geq 3 \cdot 10^{-3}$
1	The factor may only cause damage in occasional circumstances or due to an unlucky combination of events. No occurrences are known, or they have been rare. There is a correlation between the procedure and a positive trend in the accident rate and/or the rate of occupational illness over a significant period (three to five years). The likelihood of an accident is $< 3 \cdot 10^{-3} \text{ e } > 3 \cdot 10^{-5}$

Assignment of risk categories

To assign a risk category, the two indicators, D and P, must be correlated by placing them on Cartesian axes and taking the value assigned on a sectorial basis as reference:

D INDEX (POTENTIAL DAMAGE)	3	C	D	D
	2	B	C	D
	1	A	B	C
	0	A	A	B
		1	2	3
P INDEX (PROBABILITY OR FREQUENCY OF EVENTS)				

Risk categories are assigned as follows:

A-SLIGHT: Risk conditions for which the monitoring of the potential hazards has to be maintained or implemented.

B-MINOR: Risk conditions for which monitoring of the potential hazards has to be established to identify any increase.

C-MODERATE, D-HIGH: Risk conditions for which preventive and protective measures have to be adopted to reduce the risks in relation to the degree of risk identified.

MARKING THE GROUND FOR SHELVING DIMENSIONS

Operation

Marking the shelving dimensions on the ground (installation of “fixed wiring”).

Work place

Location where the shelving will be installed.

! Type of risk

Possible interference, to be assessed on a case-by-case basis, with activities carried out at the same time (e.g. installation of electrical or air-conditioning systems, masonry finishing operations).

Preparations and equipment required to guarantee compliance with the regulations

Da valutare volta per volta in base alle caratteristiche del luogo di installazione.

Performance procedures

To be evaluated each time depending on the place of installation.

TRANSPORTATION OF ERREX COMPONENTS TO THE WORK SITE

Operation

Unloading of shelving system components from the truck.

Work place

As specified in plan.

! Type of risk

Small metal parts (metal fasteners, etc.) striking workers.

Preparations and equipment required to guarantee compliance with the regulations

Such loads must only be lifted using metal buckets or bins; the use of open platforms or slings is not permitted (art. 58 of Italian Presidential Decree 164/56).

Performance procedures

Informing of workers with regard to the procedures to be adopted when lifting (raising and lowering) loads.

If the material for unloading is not in small pieces, bundles of sections or other materials may be lifted with two slings of the same length with the aiding of lifting machinery (e.g. a truck-mounted crane).

Damage index: 2

Probability index: 2

Risk index: C

! Type of risk

Bruises to the head.

Preparations and equipment required to guarantee compliance with the regulations

Use of hard helmet.

Damage index: 2

Probability index: 2

Risk index: C

! Type of risk

Bruises to the feet.

Preparations and equipment required to guarantee compliance with the regulations

Use of puncture resistant safety footwear.

Damage index: 2

Probability index: 1

Risk index: B

! Type of risk

Cuts or grazes to the hands.

Preparations and equipment required to guarantee compliance with the regulations

Use of protective gloves.

Damage index: 1

Probability index: 2

Risk index: B

! Type of risk

Back injury.

Preparations and equipment required to guarantee compliance with the regulations

Assess loads during this stage. In general, if the average weight lifted by a person is more than 25 kg, there is a risk of back injury.

Depending on the company, this general statement must be backed up by a risk assessment (pursuant to Italian Decree Law 81/2008) bearing in mind all parameters (actual weight of the load, handling conditions, frequency, etc.) required to provide a complete risk assessment.

If risks of this kind are actually identified, the employer (contractor performing the installation) must fulfil all the obligations required by Decree Law n. 81/2008, (health monitoring, information and training of workers).

Damage index: 2

Probability index: 2

Risk index: C

STORAGE OF ERREX COMPONENTS

Operation

Creation of a storage area for the materials.

Work place

To be specified in the plan.

! Type of risk

Material falling onto people.

Preparations and equipment required to guarantee compliance with the regulations

The materials must be placed or stacked in such a way as to prevent collapse or overturning (Decree Law 81/2008). Use helmets and puncture resistant safety footwear.

Performance procedures

Provide the workers concerned with instructions on the way in which the materials are to be stacked and where to stack them.

Damage index: 2

Probability index: 2

Risk index: C

! Type of risk

Fire caused by flammable materials (paints, solvents, etc.).

Preparations and equipment required to guarantee compliance with the regulations

Even small amounts of flammable materials (paints, solvents) must be stored away from sources of heat, equipment which causes sparks, and electrostatic discharges, and must be in sealed containers.

No smoking signs must be provided in the places where these materials are stored.

A class 13A - 89BC powder fire extinguisher must be provided in the store containing this material. If more than small amounts of flammable materials are present, the number of extinguishers must be increased, and units with extinguishing capacity of at least 21A 89BC must be installed.

If, for example, the quantity of paint exceeds 500 kg, fire prevention certification must be applied for (point 20 of Ministerial Decree of 16/2/1982). The access door to the store must have a raised threshold to prevent leaks.

A ventilation opening should be provided (as a guideline, at least 1/100 of the floor area of the room).

Damage index: 2

Probability index: 1

Risk index: B

! Type of risk

Cuts or grazes to the hands.

Preparations and equipment required to guarantee compliance with the regulations

Use of protective gloves.

Damage index: 1

Probability index: 2

Risk index: B

ASSEMBLING THE UPRIGHT FRAMES

Operation

Assembly of the various elements which make up the upright frames using bolts, and transfer of the assembled upright frame from the work-surface (trestles) to the storage position (which may be temporary deposit in the installation site).

Work place

As specified in plan.

! Type of risk

Noise exposure

Preparations and equipment required to guarantee compliance with the regulations

Noise assessment (Decree Law 277/91).

Performance procedures

The use of ear plugs or ear defenders is recommended when using an electric screwdriver (as a precautionary measure).

Damage index: 2

Probability index: 1

Risk index: B

! Type of risk

Cuts or grazes to the hands.

Preparations and equipment required to guarantee compliance with the regulations

Use of protective gloves.

Performance procedures

Draw up a procedure for the manual handling of the upright frames on the basis of the results of the health monitoring operations and the characteristics of the loads (NIOSH regulations).

Damage index: 2

Probability index: 1

Risk index: B

! Type of risk

Bruises to the feet.

Preparations and equipment required to guarantee compliance with the regulations

Use of puncture resistant safety footwear.

Damage index: 2

Probability index: 1

Risk index: B

! Type of risk

Back injury due to the manual handling of loads.

Preparations and equipment required to guarantee compliance with the regulations

Assess loads during this stage. In general, if the average weight lifted by a person is more than 25 kg, there is a risk of back injury.

Depending on the company, this general statement must be backed up by a risk assessment bearing in mind all parameters (actual weight of the load, handling conditions, frequency, etc.) required to provide a complete risk assessment.

If risks of this kind are actually identified, the employer (contractor performing the installation) must fulfil all the obligations required by Decree Law n. 81/2008, (health monitoring, information and training of workers).

Damage index: 2

Probability index: 2

Risk index: C

! Type of risk

Injury due to the exposure of the upper limbs to vibration during the use of electric or pneumatic screwdrivers.

Preparations and equipment required to guarantee compliance with the regulations

In generale la somma vettoriale delle accelerazioni rilevate sui tre assi in condizioni normali di impiego supera i 5 m/s^2 . Tale valore è accettato dalla letteratura scientifica come "soglia di intervento" al di sopra della

quale occorre prevedere misure di prevenzione e protezione. In questo caso è da prescriversi l'uso di guanti antivibrazione e la sorveglianza sanitaria.

Damage index: 2

Probability index: 2

Risk index: C

! Type of risk

Knocks to the head.

Preparations and equipment required to guarantee compliance with the regulations

Use of protective helmet.

Damage index: 2

Probability index: 2

Risk index: C

! Type of risk

Electrocution due to the use of electric screwdrivers.

Preparations and equipment required to guarantee compliance with the regulations

Portable devices (electric screwdrivers) must have double insulation (class II) identified by the symbol of two concentric squares.

Power supply sockets must be fitted with a device which prevents accidental removal of the plug. Unsecured plug sockets may be used provided they comply with the CEI 23-12 "Industrial plug sockets" standard.

Unsecured plug sockets and their power supply cables must be protected against mechanical damage.

Cables laid temporarily must be flexible (H07 RN --F) with rubber insulation with polychloroprene (PCP) or equivalent sheathing. Whether unsecured or permanently mounted, plug sockets must have at least IP44 protection. In particularly hazardous work site environments (presence of water, etc.) use of a higher degree of protection (IP55 or IP67) should be considered.

Portable devices must be connected to an electricity supply system fitted with a high-sensitivity differential safety breaker having tripping threshold I_d of 30 mA or below; a single differential safety breaker may protect up to 6 sockets on the same panel.

For overload protection, a magnetothermic switch must be installed for each socket, unless the power supply to the panel is protected by a single magnetothermic switch having rated current the same as the lowest of the rated currents of the plug sockets.

The power supply panel must have protection appropriate to the environment where it is used (at least IP43).

Damage index: 3

Probability index: 1

Risk index: C

TRANSPORTATION OF UPRIGHT FRAMES AND SHELVING TO THE INSTALLATION SITE

Operation

Transfer of assembled upright frames, beams and bolts by fork-lift truck from store to installation position.

Work place

Route from store to installation site.

! Type of risk

Hitting of workers with parts of the upright frames which project from the fork-lift truck during transport.

Preparations and equipment required to guarantee compliance with the regulations

Provide traffic lanes of suitable width for the dimensions of the load and the characteristics of the work site.

Safety helmets must be worn both by the fork-lift truck driver and the workers on the work site.

Damage index: 2

Probability index: 1

Risk index: B

! Type of risk

Hitting of workers with parts of the upright frames which project from the fork-lift truck during transport.

Preparations and equipment required to guarantee compliance with the regulations

Place the load on the fork-lift truck in accordance with the instructions provided by the truck's manufacturer, to ensure that it does not fall off in transit.

Improve the driver's front view by placing the transported load, in accordance with the instructions provided by the manufacturer of the fork-lift truck, in such a way that it does not obstruct the lines of vision needed for safe driving (note that an incorrectly positioned load distracts the driver's attention, meaning that he pays less attention to any people present in the vicinity).

Anyone assigned to follow the transported load from close at hand should wear a high-visibility vest.

Damage index: 2

Probability index: 1

Risk index: B

! Type of risk

Overturning of the fork-lift truck.

Preparations and equipment required to guarantee compliance with the regulations

Ensure that the fork-lift truck driver receives suitable training;

The driving position must have appropriate protection against crushing in the event that the truck overturns (in general, this protection is provided by fitting the truck with an enclosed cab).

When reversing, fork-lift truck drivers must be assisted by a person on the ground. Passengers must not be carried unless permitted by the truck's manufacturer in the driver's cab.

Damage index: 3

Probability index: 1

Risk index: C

! Type of risk

Improper use of the fork-lift truck.

Preparations and equipment required to guarantee compliance with the regulations

No workers who have not received the information, training and instruction required by the relevant regulations must be allowed to use fork-lift trucks.

Damage index: 1

Probability index: 2

Risk index: B

! Type of risk

Accidental operation of load handling controls.

Preparations and equipment required to guarantee compliance with the regulations

For fork-lift trucks placed on the market, and/or put into service before Presidential Decree no. 459/96 came into force, and which do not have the CE marking pursuant to the "Machinery Directive".

- All load control devices must have automatic return to the idle position;
- Load control devices must be of the "hold-to-run" type and operated by electrical, mechanical or other systems;

- Load control devices must be placed and arranged in such a way that they cannot be accidentally operated, especially with regard to the specified route for access to the vehicle's driving and control position (see Ministry of Labour and Social Security Circular no. 50/98).

For fork-lift trucks with CE marking, the measures specified above do not apply, since this marking confirms that the manufacturer has complied with the essential safety requirements for the machine (Presidential Decree no. 459/1996).

Damage index: 2

Probability index: 2

Risk index: C

! Type of risk

Shearing or crushing of parts of the operator's body by parts of the fork-lift truck moving in relation to each other.

Preparations and equipment required to guarantee compliance with the regulations

Chains, sprockets or other moving parts in any way accessible to the drivers or others must be fully protected by means of guards.

As an alternative to these guards, "safety distances" between moving parts are equally acceptable (see Ministry of Labour and Social Security Circular no. 50/98).

Damage index: 2

Probability index: 2

Risk index: C

! Type of risk

Noise exposure.

Preparations and equipment required to guarantee compliance with the regulations

The use of ear plugs or ear defenders is recommended (as a precautionary measure).

Damage index: 2

Probability index: 1

Risk index: B

ASSEMBLY OF SOME SHELVING TO STRENGTHEN THE STRUCTURE

Operation

Lifting the abutments and attaching them to the shelving.

Work place

As envisaged by the design.

! Type of risk

Cuts or grazes to the hands.

Preparations and equipment required to guarantee compliance with the regulations

Use of protective gloves.

Damage index: 2

Probability index: 1

Risk index: B

! Type of risk

Bruises to the feet.

Preparations and equipment required to guarantee compliance with the regulations

Use of puncture resistant safety footwear.

Damage index: 2

Probability index: 1

Risk index: B

! Type of risk

Back injury due to the manual handling of loads.

Preparations and equipment required to guarantee compliance with the regulations

Assess loads during this stage. In general, given the average weight of the upright frames (90 - 150 kg) it can be stated that there is a risk of back injury.

In this case the employer (contractor performing the installation) must fulfil all the obligations required by Decree Law no. 81/2008, (health monitoring, information and training of workers).

Damage index: 2

Probability index: 2

Risk index: C

! Type of risk

Blows from falling material.

Preparations and equipment required to guarantee compliance with the regulations

Use of protective helmet.

Damage index: 3

Probability index: 1

Risk index: C

! Type of risk

Upright frame becoming unbalanced and falling due to incorrect handling, hitting workers.

Performance procedures

Draw up a appropriate assembly procedure, complete with any hand signals for communications (see Decree Law 493/96).

Damage index: 3

Probability index: 1

Risk index: C

! Type of risk

Injury due to the exposure of the upper limbs to vibration during the use of electric or pneumatic screwdrivers.

Preparations and equipment required to guarantee compliance with the regulations

In general, the vector sum of the accelerations measured on the three axes in normal conditions of use exceeds 5 m/s².

In the scientific literature, this value is accepted as the “trigger threshold” above which preventive and protective measures must be taken. In this case, the use of vibration-damping gloves and health monitoring must be enforced.

Damage index: 2

Probability index: 2

Risk index: C

! Type of risk

Electrocution due to the use of electric screwdrivers.

Preparations and equipment required to guarantee compliance with the regulations

Portable devices (electric screwdrivers) must have double insulation (class II) identified by the symbol of two concentric squares.

Power supply sockets must be fitted with a device which prevents accidental removal of the plug.

Unsecured plug sockets may be used provided they comply with the CEI 23-12 “Industrial plug sockets” standard. Unsecured plug sockets and their power supply cables must be protected against mechanical damage.

Cables laid temporarily must be flexible (H07 RN --F) with rubber insulation with polychloroprene (PCP) or equivalent sheathing. Whether unsecured or permanently mounted, plug sockets must have at least IP44 protection. In particularly hazardous work site environments (presence of water, etc.) use of a higher degree of protection (IP55 or IP67) should be considered.

Portable devices must be connected to an electricity supply system fitted with a high-sensitivity differential safety breaker having tripping threshold I_d of 30 mA or below; a single differential safety breaker may protect up to 6 sockets on the same panel. For overload protection, a magnetothermic switch must be installed for each socket, unless the power supply to the panel is protected by a single magnetothermic switch having rated current the same as the lowest of the rated currents of the plug sockets.

The power supply panel must have protection appropriate to the environment where it is used (at least IP43).

Damage index: 3

Probability index: 1

Risk index: C

ASSEMBLY OF INTERMEDIATE SHELVING, ACCESSORIES, BRACING AND STRINGERS

Operation

Assembly of the shelving and accessories at a height exceeding 2 m.

Work place

As envisaged by the design.

! Type of risk

Cuts or grazes to the hands.

Preparations and equipment required to guarantee compliance with the regulations

Use of protective gloves.

Damage index: 2

Probability index: 1

Risk index: B

! Type of risk

Bruises to the feet.

Preparations and equipment required to guarantee compliance with the regulations

Use of puncture resistant safety footwear.

Damage index: 2

Probability index: 1

Risk index: B

! Type of risk

Back injury due to the manual handling of loads.

Preparations and equipment required to guarantee compliance with the regulations

Assess loads during this stage. In general, since the average weight of the elements handled is 20 kg (to be subdivided by the two workers who assemble the parts), the risk of back injury can be considered to be under control and therefore acceptable.

If a risk of this kind is actually identified, the employer (contractor performing the installation) must fulfil all the obligations required by Decree Law no. 81/2008, (health monitoring, information and training of workers).

Damage index: 2

Probability index: 1

Risk index: B

! Type of risk

Injuries due to falling objects.

Preparations and equipment required to guarantee compliance with the regulations

Use of safety helmet for both the assigned workers and for other workers present during the operation (also those from other companies).

Damage index: 3

Probability index: 1

Risk index: C

! Type of risk

Fall from height.

Preparations and equipment required to guarantee compliance with the regulations

Use of motorised and other equipment allowing work to be carried out using platforms fitted with parapets. Working cages lifted by lifting equipment may also be used within the limits set by art. 184 of Presidential Decree no. 547/55 and further to the installation of effective cage (or basket) safety devices as envisaged by Ministry of Labour and Social Security Circular no. 103/98.

A properly anchored safety harness can be used only where the use of equipment of this kind is not possible (e.g. during installation with aisles less than 1.70 – 1.50 metres wide).

Damage index: 3

Probability index: 2

Risk index: D

! Type of risk

Injury due to the exposure of the upper limbs to vibration during the use of electric or pneumatic screwdrivers.

Preparations and equipment required to guarantee compliance with the regulations

In general, the vector sum of the accelerations measured on the three axes in normal conditions of use exceeds 5 m/s². In the scientific literature, this value is accepted as the “trigger threshold” above which preventive and protective measures must be taken. In this case, the use of vibration-damping gloves and health monitoring must be enforced.

Damage index: 2

Probability index: 2

Risk index: C

! Type of risk

Electrocution due to the use of electric screwdrivers.

Preparations and equipment required to guarantee compliance with the regulations

Portable devices (electric screwdrivers) must have double insulation (class II) identified by the symbol of two concentric squares. Power supply sockets must be fitted with a device which prevents accidental removal of the plug. Unsecured plug sockets may be used provided they comply with the CEI 23-12 “Industrial plug sockets” standard. Unsecured plug sockets and their power supply cables must be protected against mechanical damage. Cables laid temporarily must be flexible (H07 RN --F) with rubber insulation with polychloroprene (PCP) or equivalent sheathing. Whether unsecured or permanently mounted, plug sockets must have at least IP44 protection. In particularly hazardous work site environments (presence of water, etc.) use of a higher degree of protection (IP55 or IP67) should be considered. Portable devices must be connected to an electricity supply system fitted with a high-sensitivity differential safety breaker having tripping threshold I_d of 30 mA or below; a single differential safety breaker may protect up to 6 sockets on the same panel. For overload protection, a magnetothermic switch must be installed for each socket, unless the power supply to the panel is protected by a single magnetothermic switch having rated current the same as the lowest of the rated currents of the plug sockets.

The power supply panel must have protection appropriate to the environment where it is used (at least IP43).

Damage index: 3

Probability index: 1

Risk index: C

PAINTING OF SMALL AREAS OF METAL COMPONENTS

Operation

Painting with paints or enamels.

Work place

Shelving system.

! Type of risk

Inhalation of harmful chemicals (solvents).

Preparations and equipment required to guarantee compliance with the regulations

Follow the instructions provided in the product safety information; in all cases, a facial half-mask with A2 filter is recommended.

Damage index: 2

Probability index: 2

Risk index: C

! Type of risk

Contact between skin and harmful chemicals (solvents, paints).

VERTICALITY CHECKS AND INSPECTIONS FOR CORRECT INSTALLATION

Preparations and equipment required to guarantee compliance with the regulations

Follow the instructions provided in the product safety information; in all cases, chemical-resistant gloves should be worn.

Damage index: 2

Probability index: 2

Risk index: C

! Type of risk

Knocks to the head from collisions with shelving system elements.

Preparations and equipment required to guarantee compliance with the regulations

Use of protective helmet.

Damage index: 2

Probability index: 1

Risk index: B

! Type of risk

Foot crushing or puncturing.

Preparations and equipment required to guarantee compliance with the regulations

Use of puncture resistant safety footwear.

Damage index: 2

Probability index: 1

Risk index: B

! Type of risk

Fire or explosion.

Preparations and equipment required to guarantee compliance with the regulations

Do not carry out painting jobs while open flames are used, or sparks or electrostatic charges are generated, in the vicinity.

Do not leave paint containers open.

Damage index: 2

Probability index: 1

Risk index: B

Operation

Inspection of parts, including at high level, of the shelving.

Work place

Shelving.

! Type of risk

Fall from height.

Preparations and equipment required to guarantee compliance with the regulations

Use of motorised and other equipment allowing work to be carried out using platforms fitted with parapets.

Working cages lifted by lifting equipment may also be used within the limits set by art. 184 of Presidential Decree no. 547/55 and further to the installation of effective cage (or basket) safety devices as envisaged by Ministry of Labour and Social Security Circular no. 103/98.

A properly anchored safety harness can be used only where the use of equipment of this kind is not possible (e.g. during installation with aisles less than 1.70 – 1.50 metres wide).

Damage index: 3

Probability index: 2

Risk index: D

! Type of risk

Knocks to the head from collisions with shelving system elements.

Preparations and equipment required to guarantee compliance with the regulations

Use of protective helmet.

Damage index: 2

Probability index: 2

Risk index: C

! Type of risk

Foot crushing or puncturing.

Preparations and equipment required to guarantee compliance with the regulations

Use of puncture resistant safety footwear.

Damage index: 2

Probability index: 1

Risk index: B

Operation

Inspection of parts, including at high level, of the shelving.

Work place

Shelving.

! Type of risk

Falls from height involving workers/other people.

Preparations and equipment required to guarantee compliance with the regulations

Use of motorised and other equipment allowing work to be carried out using platforms fitted with parapets. Working cages lifted by lifting equipment may also be used within the limits set by art. 184 of Presidential Decree no. 547/55 and further to the installation of effective cage (or basket) safety devices as envisaged by Ministry of Labour and Social Security Circular no. 103/98.

A properly anchored safety harness can be used only where the use of equipment of this kind is not possible (e.g. during installation with aisles less than 1.70 – 1.50 metres wide).

Damage index: 3

Probability index: 2

Indice di rischio: D

! Type of risk

Falling of material placed on the pallet rack profiles for load tests.

Preparations and equipment required to guarantee compliance with the regulations

Use of protective helmets; fencing of the entire area involved with movable barriers and placing of a suitable number of warning signs stating “No pedestrian access” or “No unauthorised access”, as appropriate.

Damage index: 2

Probability index: 2

Risk index: C

! Type of risk

Foot crushing or puncturing.

Preparations and equipment required to guarantee compliance with the regulations

Use of puncture resistant safety footwear.

Damage index: 2

Probability index: 1



**Dalmine Logistic Solutions Srl
Headquarters:**

29122 Piacenza - Italy
viale del Commercio, 36
phone +39 . 0523 17 37 911

**news@dalmine.com
www.dalmine.com**

Codice: MAN ERX 01 2 09 2015